

Go-Filter™ Mobile Treatment System

January 2013



SYSTEM OVERVIEW: TURBIDITY REDUCTION

The Go-Filter™ Mobile Treatment System is a modular trailer mounted water quality device designed to reduce turbidity levels in discharge waters at construction sites or industrial facilities without the use of environmentally harmful flocculants or chemicals. The system includes a trash pump that conveys captured stormwater runoff from a collection pond or storage vessel at flow rates up to 250 gpm (16 L/s). Pretreatment removes coarse material through a self-cleaning inline gross pollutant separator and strainer. Primary treatment is accomplished by two parallel self-cleaning cross-flow (centrifugal) sand filters that use PathShield™ media, a proprietary media manufactured by A S Filtration™. Backwash water is derived from a separate 800 gallon polypropylene storage tank. Treated water is discharged the backwash water storage tank; and when full, then directly to a receiving water body or other conveyance mechanism. The low maintenance Go-Filter™ is powered by a single connection using electricity or generator. Site-specific rental options are available.

HIGH PERFORMANCE

The Go-Filter™ achieves over 90% turbidity reduction with discharge levels on the order of 10 to 20 NTUs (Nephelometric Turbidity Units), depending on the influent level. As opposed to conventional sand filters, cross-flow filtration technology achieves 95% solids removal to the submicron level (0.5 microns, 0.0005 mm). Removal of fine silt and clay sized particles provides for very low effluent turbidity levels thereby meeting the most stringent NPDES permit discharge limits.

MODE of OPERATION

The unique Go-Filter™ design incorporates a self-cleaning inline gross pollutant separator and strainer for pretreatment followed by two cross-flow (centrifugal) sand filters configured in parallel charged with PathShield™ media for primary treatment. When compared to traditional sand filters, the Go-Filter™ achieves high performance efficiency using cross-flow filtration technology which maximizes contact time

between the suspended sediment and the proprietary sand filter media. This radial cross-flow design traps particles at the surface of the media bed instead of deep within a media bed such as a traditional sand filter. This allows the Go-Filter™ technology to use 50% less backwash water than traditional filters. Conversely, traditional sand filters rely on forcing suspended particles deep into the media bed to improve sediment removal efficiency; hence, its ability to transmit water is diminished with increasing particle loading. This decreased flow capacity results in increased difficulty for backwashing since more water, time and energy is needed to remove the trapped material.

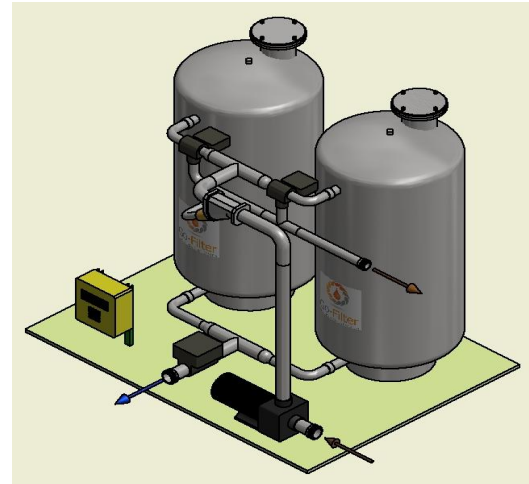

The Go-Filter™ treatment process is described in the following five steps:

Step 1. Water Supply and Flow Rate

The self priming trash pump conveys captured stormwater runoff from a collection pond or storage vessel at flow rates up to 250 gpm (16 L/s). Since the Go-Filter™ also treats industrial wastewater, other means can be applied in order to direct water to the treatment system.

Step 2. Pretreatment

Pretreatment is accomplished at the selected flow rate when coarse material is removed from the treatment flow through the use of a self-cleaning inline pollutant separator and strainer. Backwash water derived from a separate 800 gallon plastic storage tank is used to clean the strainer without the need to periodically shut down operations for cleaning.

Step 3. Primary Treatment

Primary treatment is accomplished at the selected flow rate by two parallel cross-flow sand filters using PathShield™ media. Each filter consists of a 36-inch (91 cm) diameter stainless steel ASME certified vessel. The

filtration assembly includes an automated control panel and associated switches, valves, strainers and piping.

Step 4. Backwash Cycles

Both cross-flow filters and inline pretreatment strainer are self-cleaning through backwashing cycles. Backwashing utilizes a dedicated 800 gallon polypropylene water storage vessel. Backwash cycles, using the stored treated water, are triggered automatically by pressure differentials resulting from particle accumulation within the filters and have typical durations of four to eight minutes. Automatic backwashing eliminates the need to shut down operations to manually perform routine filter or strainer cleaning thereby reducing operational costs.

Step 5. Discharge

Post-filtration (treated) water exits the filters through a flexible hose at the same flow rate of the trash pump. The discharge hose runs from the filter assembly to a designated discharge point away from the trailer. No additional treatment is necessary once water is discharged from the system.

QUICK SETUP and LOW MAINTENANCE

The Go-Filter™ is a mobile water treatment system that provides operational flexibility to a site or industrial facility. All system components are mounted on a road-ready trailer to provide for quick and easy setup. Once positioned at a suitable location, the influent and effluent hose connections can be made. The influent hose to the self priming trash pump should extend to the water source whereby the intake includes a floatation assembly allowing water to be skimmed from the top of the water source. The backwash water hose is quickly connected between the filtration assembly and the storage tank. The discharge hose should extend sufficiently away from the trailer and directed to the desired discharge point. The Go-Filter™ operates on 220V power, either on-site or supplied via portable generator.

The Go-Filter™ design incorporates automated system controls to minimize maintenance tasks and system downtime while achieving cost-effective and high levels of treatment. Following startup, AquaShield™ recommends that regular inspections of the trailer components, intake hose, backwater water assembly and discharge hose be performed to ensure that the system is operating as designed and to avoid potential system damage and shut down in the event of a malfunction.

AquaShield™ will perform any necessary system repairs beyond that of routine component cleaning and adjustments as warranted in accordance with the project's Rental Agreement. An Operations Manual is

provided for each site delivery and includes an Inspection and Maintenance Log to assist with tracking and anticipating operational activities to maximize system efficiency.

GO-FILTER™ BENEFITS

High Performance

The Go-Filter™ Mobile Treatment System uses high performance cross-flow (centrifugal) filtration technology and PathShield™ media to achieve 95% removal of fine suspended solids and particles down to 0.5 microns in size. Treatment is provided at flow rates up to 250 gpm (16 L/s). Cross-flow filtration removes smaller particles than traditional sand filters which serves to enhance the turbidity reduction capability. Over 90% turbidity reduction can be achieved by the Go-Filter™.

Eliminates Chemicals

The Go-Filter™ technology completely eliminates the use of environmentally harmful and costly flocculants or chemicals while still meeting stringent NPDES permit discharge limits. Storage and handling concerns associated with chemical water treatment are also eliminated. As a result, overall operational costs are reduced when using the Go-Filter™.

Quick Setup and Easy Operation

Its modular small footprint design eliminates need for extensive on-site assembly and facilitates quick and easy setup for temporary or long term operations. The use of automated controls and common construction site components do not require lengthy training in order to initiate operations. The Go-Filter™ system operates by a single connection using electrical power. The self cleaning cross-flow filters use less energy, water and time for backwash cycles compared to traditional sand filters.

Rental Options

Various rental options are available for the Go-Filter™.

Backed by AquaShield™

AquaShield™ is a leading manufacturer of stormwater treatment systems including the Aqua-Swirl®, Aqua-Filter™, Aqua-Guardian™, AquaShield™ Bio-Filter™, and the Go-Filter™. Our proven track record of performance and customer service in both domestic and international arenas provides you with the highest level of confidence to use the Go-Filter™ Mobile Treatment System on your project site.

To learn more about the Go-Filter™, contact your local AquaShield™ representative, call us at (888) 344-9044, or visit our website at www.aquashieldinc.com.