



Aqua-Filter™

Stormwater Filtration System

Inspection and Maintenance Manual



AquaShield™, Inc.
2719 Kanasita Drive
Chattanooga, TN 37343
Phone: (423) 870-8888
Fax: (423) 826-2112
Email: info@aquashieldinc.com
www.aquashieldinc.com

March 2013

Page 1 of 21

© AquaShield™, Inc. 2013. All rights reserved.

Table of Contents

	<u>Page(s)</u>
• AquaShield™ Stormwater Treatment Systems	3
• Aqua-Filter™ Stormwater Treatment System	4 – 12
• Inspection and Maintenance Worksheets	13 – 18
• Aqua-Swirl® Tabular Maintenance Schedule	19

AquaShield™, Inc.
2719 Kanasita Drive
Chattanooga, Tennessee 37343
Toll free (888) 344-9044
Fax (423) 870-2112
www.aquashieldinc.com



AquaShield™, Inc Stormwater Treatment Solutions

The highest priority of AquaShield™, Inc. (AquaShield™) is to protect waterways by providing stormwater treatment solutions to businesses across the world. These solutions have a reliable foundation based on over 20 years of water treatment experience.

Local regulators, engineers, and contractors have praised the AquaShield™ systems for their simple design and ease of installation. All the systems are fabricated from high performance, durable and lightweight materials. Contractors prefer the quick and simple installation of our structures that saves them money.

The patented line of AquaShield™ stormwater treatment products that provide high levels of stormwater treatment include the following:

- **Aqua-Swirl® Stormwater Treatment System:** hydrodynamic separator, which provides a highly effective means for the removal of sediment, floating debris and free-oil.
- **Aqua-Filter™ Stormwater Filtration System:** treatment train stormwater filtration system capable of removing gross contaminants, fine sediments, waterborne hydrocarbons, heavy metals and total phosphorous.



Aqua-Swirl®



Filtration Chamber of Aqua-Filter™ system



Aqua-Filter™ Stormwater Filtration System

The Aqua-Filter™ Stormwater Filtration System is designed for projects that require advanced treatment of stormwater runoff. Each system is custom engineered for site-specific needs. The patented Aqua-Filter™ system utilizes a unique “treatment-train” approach that includes an Aqua-Swirl® hydrodynamic separator for pretreatment followed by a filtration chamber for secondary treatment. A variety of natural filter media are used in order to complete the treatment process by polishing the stormwater prior to discharge. Independent laboratory and field performance verifications have shown that the Aqua-Filter™ system achieves over 80% suspended solids removal efficiency on a net annual basis.

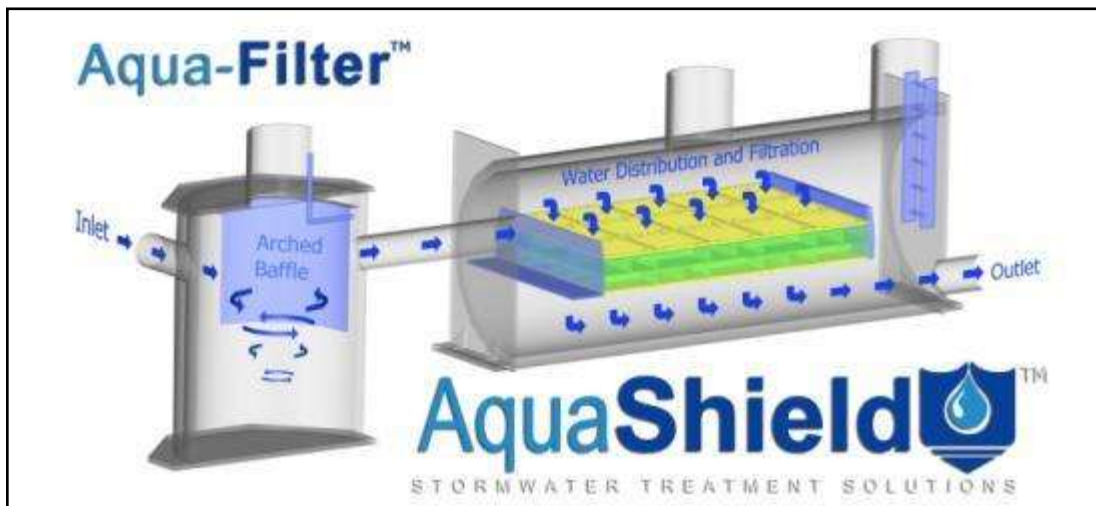

Aqua-Filter™ Stormwater Filtration System showing Aqua-Swirl® for pretreatment followed by filtration chamber for secondary treatment prior to discharge.

The Aqua-Filter™ Stormwater Filtration System is designed for sites that require advanced treatment of runoff stormwater to meet stringent discharge requirements. Each Aqua-Filter™ system is custom engineered and utilizes a unique approach for pollutant removal. This patented configuration begins with the removal of sediment, debris and free-floating oil by the Aqua-Swirl® Stormwater Treatment System, followed by the removal of fine sediments and other waterborne pollutants by the filtration chamber. The system can be designed for new construction projects or be used for retrofit applications. Inspection and maintenance are made simplified with oversized risers that allow for both examination and cleanout. An ingress/egress ladder is provided for the filtration chamber to better facilitate maintenance. Each Aqua-Filter™ is constructed of high performance, lightweight and durable materials including polymer coated steel (PCS) or high density polyethylene (HDPE). These materials eliminate the need for heavy lifting equipment during installation.

Third party performance and functionality testing has demonstrated Total Suspended Solids (TSS) removals of greater than 80% on a net annual basis. In addition, the Aqua-Filter™ is effective for the removal of other pollutants including petroleum hydrocarbons as well as total phosphorus and various heavy metals when bound to particulate material.



System Operation

The Aqua-Filter™ Stormwater Filtration System operates under gravitational and hydrodynamic forces with no moving parts or valves which simplifies the treatment process. The Aqua-Filter™ system is typically installed to operate in an off-line configuration. However, local jurisdictions may allow for in-line (on-line) installations. AquaShield™ recommends that local guidelines be confirmed during the site design process to ensure the proper installation rules for an Aqua-Filter™ system.

Step 1: Pretreatment by Aqua-Swirl®

Peripheral pretreatment of stormwater is not necessary when using the Aqua-Filter™. In fact, each Aqua-Filter™ is custom engineered to utilize a unique treatment train approach. Operation begins when stormwater enters the Aqua-Swirl® through a tangential inlet pipe that produces a circular (or vortex) flow pattern that causes contaminants to settle to the base of the unit. Since stormwater flow is intermittent by nature, the Aqua-Swirl® retains water between storm events providing both dynamic and quiescent settling of solids. The dynamic settling occurs during each storm event while the quiescent settling takes place between successive storms. A combination of gravitational and hydrodynamic drag forces encourages the solids to drop out of the flow and migrate to the center of the chamber where velocities are the lowest. The treated flow then exits the Aqua-Swirl® behind the arched outer baffle. The top of the baffle is sealed across the treatment channel, thereby eliminating floatable pollutants from escaping the system. A vent pipe is extended up the riser to expose the backside of the baffle to atmospheric conditions, preventing a siphon from forming at the bottom of the baffle.



**Aqua-Swirl® component of the Aqua-Filter™ System.
Note tangential inlet and outlet piping stubouts.**

Step 2: Secondary Treatment by Filtration Chamber

The filtration chamber in the Aqua-Filter™ is designed to refine and enhance the stormwater quality prior to discharge into sensitive receiving waters. As the pretreated water enters the filtration chamber, it is evenly distributed across the filter bed and allowed to permeate by gravity flow through the filter media. Either a downflow or upflow configuration can be used for the filtration chamber. The filter media are contained in individual and durable nylon mesh containers (bags) positioned in such manner to avoid short circuiting (see Filter Replacement).



Filtration chamber of Aqua-Filter™ system being lowered into place. Access risers are visible along the top length of the chamber.

The natural filter media used for filtration is capable of removing the remaining waterborne pollutants such as fine-grained sediment, oil, total phosphorus, and heavy metals (e.g., copper, lead, zinc). The most commonly used media is coarse perlite. Other filter media such as zeolite, granulated activated carbon, leaf compost, bone char and various proprietary media blends are available to target site-specific pollutant treatment goals and discharge limits.



AquaShield™ Product System Maintenance

The long term performance of any stormwater treatment structure, including manufactured or land based systems, depends on a consistent maintenance plan. Inspection and maintenance functions are simple and easy for AquaShield™ Stormwater Treatment Systems allowing all inspections to be performed from the surface. It is important that a routine inspection and maintenance program be established for each unit based on: (a) the volume or load of the contaminants of concern, (b) the frequency of releases of contaminants at the facility or location, and (c) the nature of the area being drained.

In order to ensure that our systems are being maintained properly, AquaShield™ offers a maintenance solution to all of our customers. We will arrange to have maintenance performed.



Distinctive AquaShield™ logo is visible on manhole covers for each system.



Filter containers (bags) are easily managed.



Inspection

All AquaShield™ products can be inspected from the surface, eliminating the need to enter the systems to determine when cleanout should be performed. In most cases, AquaShield™ recommends a quarterly inspection for the first year of operation to develop an appropriate schedule of maintenance. Based on experience of the system's first year in operation, we recommend that the inspection schedule be revised to reflect site-specific conditions being encountered. Typically, the inspection schedule for subsequent years is reduced to semi-annual inspection events.

Discussions pertaining to maintenance of the Aqua-Swirl® and Filtration Chamber are provided below



Aqua-Swirl[®] Maintenance

The Aqua-Swirl[®] has been designed to minimize and simplify the inspection and maintenance process. The single swirl chamber system can be inspected and maintained entirely from the surface thereby eliminating the need for confined space entry. There are no areas of the structure that are blocked from visual inspection or periodic cleaning. Inspection of any free-floating oil and floatable debris can be directly observed and maintained through the manhole access provided directly over the swirl chamber.

Aqua-Swirl[®] Inspection Procedure

To inspect the Aqua-Swirl[®], a hook is needed to remove the manhole cover. AquaShield[™] provides a customized manhole cover with our distinctive logo to make it easy for maintenance crews to locate a system in the field. We also provide a permanent metal information plate affixed inside the access riser which provides our contact information, the Aqua-Swirl[®] model size and serial number.

The only tools needed to inspect the Aqua-Swirl[®] system are a flashlight and a measuring device such as a stadia rod or pole. Given the easy and direct accessibility provided to the swirl chamber, floating oil and debris can be observed directly from the surface. Sediment depths can easily be determined by lowering a measuring device to the top of the sediment pile and to the surface of the water. When the sediment pile is within 42 to 48 inches of the water surface (or sediment pile thickness is 18 to 24 inches as measured from the base), the system should be maintained. The maximum sediment storage capacity of the Aqua-Swirl[®] is reached when the sediment pile is within 30 inches of the water surface (or sediment accumulation is 36 inches thick as measured from the base).

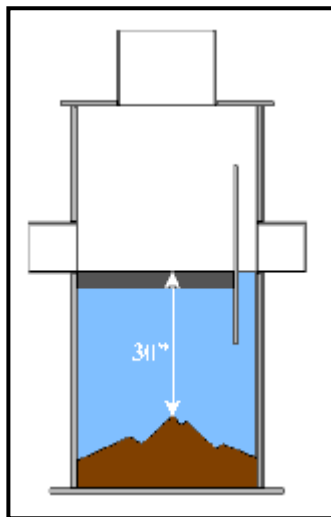

Maintain Aqua-Swirl[®] when sediment is 42-48 inches below water surface. Maximum sediment storage capacity reached when sediment is 30 inches below water surface.



Sediment inspection using a stadia rod in a single chamber.



Floatable debris in the Aqua-Swirl[®]

It should be noted that in order to avoid underestimating the volume of sediment in the chamber, the measuring device must be carefully lowered to the *top* of the sediment pile. Keep in mind that the finer sediment at the top of the pile may offer less resistance to the measuring device than the larger particles which typically occur deeper within the sediment pile. The Aqua-Swirl[®] design allows for the sediment to accumulate in a semi-conical fashion as illustrated above. That is, the depth to sediment as measured below the water surface may be less in the center of the swirl chamber; and likewise, may be greater at the edges of the swirl chamber.

Aqua-Swirl[®] Cleanout Procedure

Cleaning the Aqua-Swirl[®] is simple and quick. Free-floating oil and floatable debris can be observed and removed directly through the 30-inch service access riser provided. A vacuum truck is typically used to remove the accumulated sediment and debris. An advantage of the Aqua-Swirl[®] design is that the entire sediment storage area can be reached with a vacuum hose from the surface (reaching all the sides). Since there are no multiple or limited (hidden or “blind”) chambers in the Aqua-Swirl[®], there are no restrictions to impede on-site maintenance tasks.

Disposal of Recovered Materials from Aqua-Swirl[®]

Disposal of recovered material is typically handled in the same fashion as catch basin cleanouts. AquaShield[™] recommends that all maintenance activities be performed in accordance with appropriate health and safety practices for the tasks and equipment being used. AquaShield[™] also recommends that all materials removed from the Aqua-Swirl[®] and any external structures (e.g, bypass features) be handled and disposed in full accordance with any applicable local and state requirements.



**Vacuum truck quickly cleans the Aqua-Swirl®
from a single chamber**



Filtration Chamber Maintenance

The filter media is also easily observed from the surface. Manhole covers are spaced over the entire filtration bed to provide easy access. AquaShield™ provides a customized manhole cover with our logo to make it easy for maintenance crews to locate a system in the field. An entry riser provides direct access into the filtration chamber with a permanent ladder welded into the downstream section of the filtration chamber. This additional access allows for the vacuuming of any standing water and an unobstructed access to the downstream side of the filter bed.



**A permanent ingress/egress ladder provides access to filter chamber.
Note metal product identification plate above ladder.**

Initially, perlite filter media is light tan or white in color. When the media color turns black or dark brown, it has become saturated due to pollutant loading and requires replacement. Call toll free (888) 344-9044 to order replacement filters.

Replacement of the filtration media typically requires entry into the filtration chamber by one of a two-member maintenance crew. Confined space entry methods should be followed by the maintenance crew when removing and replacing the filters. The spent filter containers are normally retrieved from the filter chamber by a second crewmember at the surface through the multiple 30-inch risers spaced across the top of the filter bed. In addition, the filter containers can be accessed directly from within the filtration chamber via a vertical removable panel (bulkhead door) at the rear of the filter bed and directly across from the ladder.

Filter Media Disposal

Disposal of recovered material is typically handled in the same fashion as catch basin cleanouts. AquaShield™ recommends that all maintenance activities be performed in accordance with appropriate health and safety practices for the tasks and equipment being used. AquaShield™ also recommends that all materials removed from the Aqua-Swirl® and any external structures (e.g, bypass features) be handled and disposed in full accordance with any applicable local and state requirements.



Spent filter media can often be recycled or sent to a permitted lined landfill. Always check local regulations to ensure proper disposal of spent filter media.

Filter Media Replacement

Instructions and photographs are provided on page 12 showing the procedures to follow to install fresh filter media containers. The bottom of two courses is placed on the fiberglass grates. Cargo netting is used across the top course of the filter containers to secure them in place.

Cargo Netting Installation

Cargo netting is used to secure filter containers in place after containers are installed in the appropriate orientation within the filtration chamber. ***Cargo netting is placed on top of the top course of filter containers*** and stretched into place using provided heavy duty cable ties. The netting is cable tied to anchor blocks and attached to the side walls of the filtration chamber. It is important to install the netting in such a way as to both cover the entire surface area of the

containers while stretching netting snugly to minimize container movement under high flow conditions. Netting installation is complete when all surface area of filter containers are covered with netting and netting is secured with cable ties to anchor blocks.

INSTALLATION INSTRUCTIONS for FILTER CONTAINERS



(1) Bottom Grates found in chamber

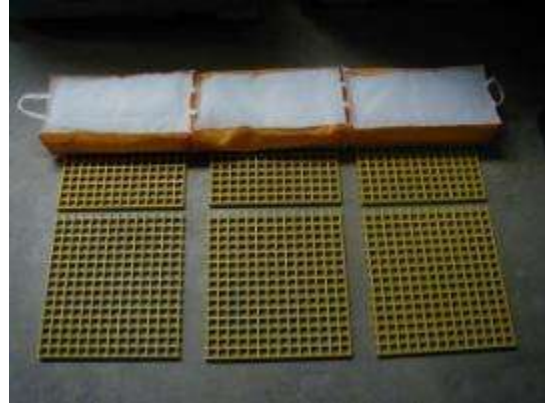

(2) First row first course



(3) Second row

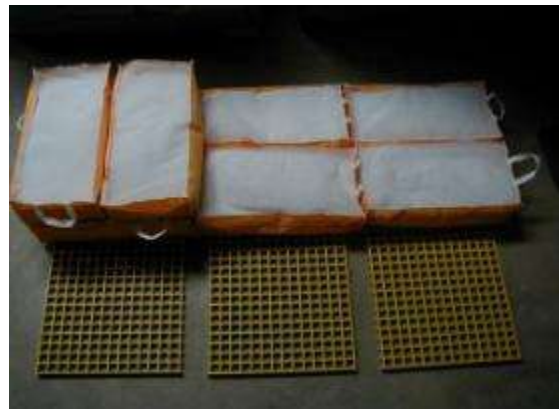

(4) Second course started



(5) Second course complete

Aqua-Filter™ Inspection and Maintenance Manual Work Sheets

SITE and OWNER INFORMATION

Site Name: _____

Site Location: _____

Date: _____ Time: _____

Inspector Name: _____

Inspector Company: _____ Phone #: _____

Owner Name: _____

Owner Address: _____

Owner Phone #: _____ Emergency Phone #: _____

INSPECTION

Note: Aqua-Filter™ system is a treatment train including Aqua-Swirl® and filtration chamber.

I. Floatable Debris and Oil in Aqua-Swirl®

1. Remove manhole lid to expose liquid surface of the Aqua-Swirl®.
2. Remove floatable debris with basket or net if any present.
3. If oil is present, measure its depth. Clean liquids from system if one half (½) inch or more oil is present.

Note: Water in Aqua-Swirl® can appear black and similar to oil due to the dark body of the surrounding structure. Oil may appear darker than water in the system and is usually accompanied by oil stained debris (e.g. Styrofoam, etc.). The depth of oil can be measured with an oil/water interface probe, a stadia rod with water finding paste, a coliwasa, or collect a representative sample with a jar attached to a rod.

II. Sediment Accumulation in Aqua-Swirl®

1. Lower measuring device (e.g. stadia rod) into swirl chamber through service access provided (Figure 1). From a reference point at the top of the service access:
2. Record distance to top of sediment pile (Figure 2): _____ inches
3. Record distance to top of water surface: _____ inches
4. Calculate distance to sediment minus distance to water: _____ inches
5. Schedule cleaning if value in Step #4 is 48 to 42 inches or less. The sediment storage capacity is exceeded when the depth to sediment is within 30 inches of the water surface and maintenance should be performed immediately.



Figure 1. Measuring sediment in swirl chamber using stadia rod. Inspections are performed from the surface through the manhole access cover.

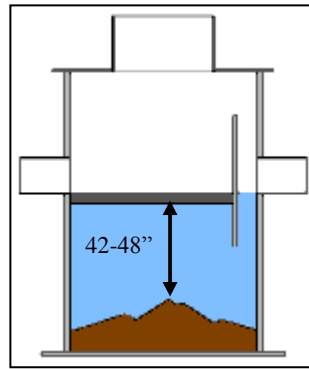

Figure 2. Maintain system when sediment is 42 to 48 inches below water surface to ensure proper system operation and performance. Maximum sediment storage capacity is reached when sediment is 30 inches below water surface.

III. Filtration Chamber

1. Remove manhole lid(s) to expose filter media bed and access ingress/egress ladder. At a minimum, one manhole lid will be present to access ladder. Larger filtration chamber sizes may have one or more manhole lids to access filter media bed.
2. Enter filtration chamber via ladder or through access riser(s) over filter bed. Note that water may be present at minimal depths in the filtration chamber prior to clean-out during inspection.
3. Remove bulkhead door (gate) at downstream end of filtration chamber and across from ladder (Figure 3).
4. Remove filter grate covers/cargo nets and filters through access risers located along filtration chamber length or through ingress/egress ladder manhole.
5. Visually inspect filter media noting color and saturation or contaminants.
6. If (perlite) media is dark brown or black, the media is fully spent and should be replaced (Figure 4).



Figure 3. Removable bulkhead door across from ingress/egress ladder at rear of filtration chamber.



Figure 4. Perlite filter media needs replacement.

7. Contact AquaShield™ for replacement filter media containers at (888) 344-9044, or info@aquashieldinc.com.
8. Schedule cleaning as described below.

IV. Diversion Structures (External Bypass Features)

Diversion (external bypass) structures should be inspected as follows:

1. Inspect weir or other bypass feature for structural decay or damage. Weirs are more susceptible to damage than off-set piping and should be checked to confirm that they are not crumbling (concrete or brick) or decaying (steel).
2. Inspect diversion structure and bypass piping for signs of structural damage or blockage from debris or sediment accumulation.
3. When feasible, measure elevations on diversion weir or piping to ensure it is consistent with site plan designs.
4. Inspect downstream (convergence) structure(s) for sign of blockage or structural failure as noted above.

CLEANING

Schedule cleaning with local vacor company or AquaShield™ to remove sediment, oil and other floatable pollutants. The spent filter containers and captured material generally does not require special treatment or handling for disposal. Site-specific conditions or the presence of known contaminants may necessitate that appropriate actions be taken to clean and dispose of materials captured and retained by the Aqua-Filter™ system. All cleaning activities should be performed in accordance with property health and safety procedures.

AquaShield™ always recommends that all materials removed from the Aqua-Filter™ system (Aqua-Swirl® and filtration chamber) during the maintenance process be handled and disposed in accordance with local and state environmental or other regulatory requirements.

MAINTENANCE SCHEDULE

I. During Construction

Inspect the Aqua-Filter™ system (Aqua-Swirl® and filtration chamber) every three (3) months and clean the system as needed. The Aqua-Filter™ should be inspected and cleaned at the end of construction regardless of whether it has reached its maintenance triggers including any of the following:

- depth to sediment is 42 to 48 inches water surface in Aqua-Swirl®,
- maximum sediment storage capacity is reached when depth to sediment is 30 inches below water surface in the Aqua-Swirl®,
- Oil is present to the degree that requires cleaning, and/or

- filter media exhibits black to dark brown color and/or is saturated with contaminants.

II. First Year Post-Construction

Inspect the Aqua-Filter™ every three (3) months and clean the system as needed.

Inspect and clean the system once annually regardless of whether it has reached its sediment or floatable pollutant storage capacity.

III. Second and Subsequent Years Post-Construction

If the Aqua-Filter™ did not reach full sediment or floatable pollutant capacity in the First Year Post-Construction period, the system can be inspected and cleaned once annually.

If the Aqua-Filter™ reached full sediment or floatable pollutant capacity in less than 12 months in the First Year Post-Construction period, the system should be inspected once every six (6) months and cleaned as needed. The Aqua-Filter™ should be cleaned annually regardless of whether it reaches its sediment or floatable pollutant capacity.

IV. Bypass Structures

Bypass structures should be inspected whenever the Aqua-Filter™ is inspected. Maintenance should be performed on bypass structures as needed.

MAINTENANCE COMPANY INFORMATION

Company Name: _____

Street Address: _____

City: _____ State/Prov.: _____ Zip/Postal Code: _____

Contact: _____ Title: _____

Office Phone: _____ Cell Phone: _____

ACTIVITY LOG

Date of Cleaning: _____ (Next inspection should be 3 months from this data for first year).

Time of Cleaning: Start: _____ End: _____

Date of Next Inspection: _____

Floatable debris present in Aqua-Swirl[®]: Yes No

Notes: _____

Oil present in Aqua-Swirl[®]: Yes No Oil depth (inches): _____

Measurement method and notes: _____

Filter Media Needs Replacement: Yes No

Filter grate / cargo netting needs repair/replacement: Yes No

Number of Filter Containers (bags) needing replacement: _____

Type of Filter Media: Perlite Other(s): _____

Other Filtration Chamber Needs and Observations: _____

STRUCTURAL CONDITIONS and OBSERVATIONS

Structural damage: Yes No Where: _____

Structural wear: Yes No Where: _____

Odors present: Yes No Describe: _____

Aqua-Filter™

TABULAR MAINTENANCE SCHEDULE

Date Construction Started: _____

Date Construction Ended: _____

During Construction

Activity	Month											
	1	2	3	4	5	6	7	8	9	10	11	12
Inspect and Clean as needed			X			X			X			X
Inspect Bypass and maintain as needed			X			X			X			X
Clean System*												X*

* Aqua-Filter™ should be cleaned **once a year** regardless of whether it has reached full pollutant storage capacity. In addition, the system should be cleaned at the **end of construction** regardless of whether it has reach full pollutant storage capacity.

First Year Post-Construction

Activity	Month											
	1	2	3	4	5	6	7	8	9	10	11	12
Inspect and Clean as needed			X			X			X			X
Inspect Bypass and maintain as needed			X			X			X			X
Clean System*												X*

* Aqua-Filter™ should be cleaned **once a year** regardless of whether it has reached full pollutant storage capacity.

Second and Subsequent Years Post-Construction

Activity	Month											
	1	2	3	4	5	6	7	8	9	10	11	12
Inspect and Clean as needed												X*
Inspect Bypass,												X*

maintain as needed												
Clean System*												X*

* If the Aqua-Filter™ did **not** reach full sediment or floatable pollutant capacity in the First Year Post-Construction period, the system can be inspected and cleaned once annually.

If the Aqua-Filter™ **reached** full sediment or floatable pollutant capacity in less than 12 months in the First Year Post-Construction period, the system should be inspected once every six (6) months or more frequently if past history warrants, and cleaned as needed. The Aqua-Filter™ should be cleaned annually regardless of whether it reaches its full sediment or floatable pollutant capacity.